

PARTS DIAGRAM

for use with "Q" serial numbers 2-year warranty

MAXXUM 70

70 LBS THRUST - 24 VOLT - 42 AMPS - 42" SHAFT

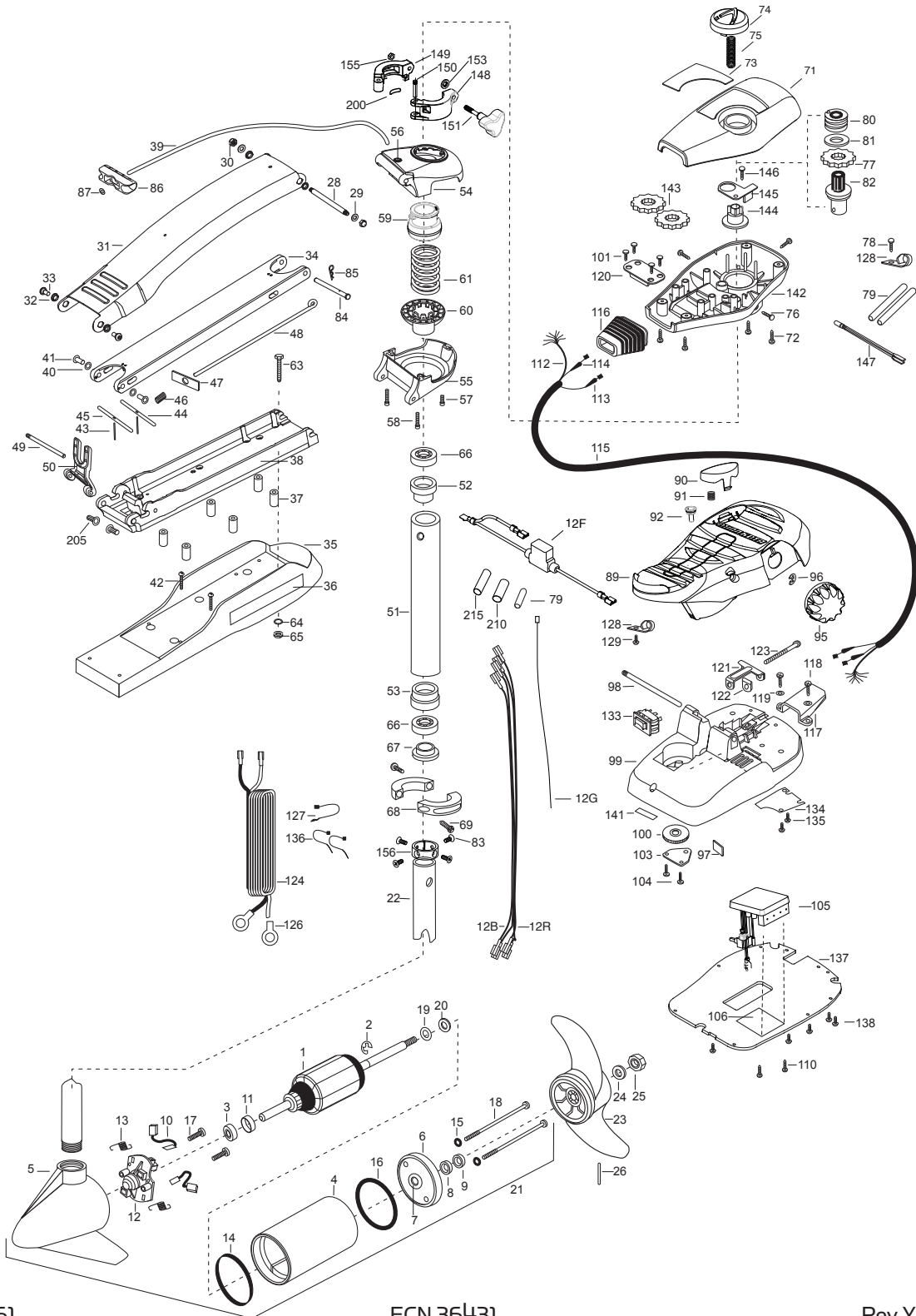

PARTS LIST

MAXXUM 70

70 LBS THRUST - 24 VOLT - 42" SHAFT

ITEM	QTY	PART NUMBER	DESCRIPTION
1	1	2-100-119	ARMATURE ASSEMBLY
2	1	788-015	RETAINING RING
3	1	140-010	BALL BEARING
4	1	431-005	CENTER HOUSING ASSEMBLY
5	1	421-065	HOUSING BRUSH END 3.62
6	1	2-400-101	PLAIN END HOUSING ASSEMBLY
7	1	144-049	BEARING - FLANGE (SERVICE CENTER ONLY)
8	1	880-003	SEAL
9	1	880-006	SEAL WITH SHIELD
10	2	188-037	BRUSH ASSEMBLY
11	1	725-050	BRUSH RETENTION- PAPER TUBE
12	1	738-036	BRUSH PLATE W/HOLDER
12B	1	640-004	LEADWIRE BLACK 10 GA
12R	1	640-105	LEADWIRE RED 10 GA
■	1	2307314	FERRITE BEAD
13	2	975-040	SPRING - TORSION
14	1	337-036	GASKET
15	2	701-008	O-RING, THRU-BOLT
16	1	701-081	O-RING
17	2	830-007	SCREW-8-32
18	2	830-008	THRU-BOLT 10-32X9.2
19	1	990-067	WASHER- STEEL THRUST
20	1	990-070	WASHER- NYLATRON
21	1	2096050	MOTOR ASSEMBLY 24V F/W
22	1	2032003	TUBE- COMPOSITE W/4 HOLE 42"
■	1	1378131	PROPELLER KIT
23	1	2091160	PROPELLER WWEDGE 2
24	1	2151726	WASHER-5/16 SS
25	1	2053101	NUT-PROP NYLOC
26	1	2092600	PIN-DRIVE
28	1	2262605	PIN- BWGRD UPPER THREADED ZP
29	2	9908236	WASHER- 1/4 FLAT ZINC
30	2	2223100	NUT- TENSION 5/16-18 SS
■	1	2991840	MOUNT- ASSEMBLY, W/O BG, STD FW MAX
31	1	2264241	ARM-UPPER STD FW
32	4	2293501	BUSHING- STAINLESS STEEL
33	2	2263500	BOLT- SHOULDER MAXXUM
34	1	2774315	ARM-LOWER ASSEMBLY,STD,FW,EXTRA [INCLUDES 39, 43-47, 86,87]
35	1	2263912	MOTOR REST (STD) FW
36	2	2265514	DECAL- MAXXUM MOTOR REST
37	6	2261505	SPACER- MOTOR REST
38	1	2773987	BOWPLATE- W/INSERT
39	1	2251601	ROPE (40"), MAXXUM MOUNT

ITEM	QTY	PART NUMBER	DESCRIPTION
40	2	2261708	WASHER- 3/8X1/2X.010 SS
41	2	2267318	BEARING NYLINER
42	2	2263434	SCREW, 8-18X1" PPH
43	2	2152610	SPRING- PIN LOCKBAR
44	1	2233600	LOCK BAR- BOW MOUNT
45	1	2233602	LOCK BAR REAR - ZINC
46	1	2152700	SPRING- LOCKBAR CAD.PLTD
47	1	2262703	SPRING STOP- MAXXUM
48	1	2153602	EYE SHAFT-2LOCKBAR STD
49	1	2260506	HINGE- PIN HEADLESS ZINC
50	1	2293811	YOKE- MAXXUM MOUNT,POLYPROPYLENE
■	1	2772012	TUBE W/BEARING RACE ASSEMBLY
51	1	2272069	TUBE OUTER-21" 4 HOLES
52	1	2266260	BEARING RACE
53	1	2266220	BEARING RACE- STEEL
■	1	2991762	BOWGUARD ASSEMBLY- FT CTRL,FW
54	1	2772319	BRACKET BASE TOP/ EYELET ASSEMBLY
*55	1	2991771	BRKT BOTTOM/BEARING FW ASSEMBLY
56	1	2772352	EYELET- KIT
57	1	2263423	SCREW 5/16-18 X 1" SHCS ZINC
58	2	2263425	SCREW 5/16-18 X 2 1/2" SHCS
59	1	2071541	SPRING SLEEVE- UPPER
60	1	2071535	SPRING SLEEVE- LOWER
61	1	2262712	SPRING- BOWGUARD, NIK PL
■	1	2994830	BAG ASSEMBLY- MAXXUM
*63	6	2263431	SCREW- 1/4-20 X 3.5 PPH
*64	6	2261713	WASHER- 1/4 FLAT S/S
*65	6	2263103	NUT- 1/4-20 NYLOCK-JAM SS
66	2	2266000	BEARING BALL- STEEL
*67	1	2266115	BEARING CONE
*68	2	2261619	COLLAR HALF- ZINC
*69	2	2263452	SCREW- 1/4-20X3/4
71	1	2280201	CONTROL BOX COVER
72	4	2372100	SCREW- 8-18 X 5/8 THD
73	1	2275604	DECAL- COVER MAX70/FC
74	1	2990140	DIRECTIONAL INDICATOR
75	1	2282730	SPRING - INDICATOR
76	3	2053414	SCREW- 8-32 X 1/2 TRI-LOBE
77	1	2267800	GEAR- INDICATOR
78	1	2372100	SCREW- 8-18 X 5/8
79	3	2355410	SHRINK TUBE- 3/8 OD X 2"
80	1	2232360	PULLEY- CABLE DRUM
81	1	2261730	WASHER- NYLON A/T CON
82	1	2996247	TOP BEARING RACE /PINION DRIVE

PARTS LIST

MAXXUM 70 70 LBS THRUST - 24 VOLT - 42" SHAFT

ITEM	QTY	PART NUMBER	DESCRIPTION
83	4	2223468	SCREW- 8-32 X 7/16
84	1	2262607	PIN- CLEVIS ZP MAXXUM BWGRD
85	1	2260805	CLIP- SPRING ZP MAX BG
86	1	2150400	PULL- GRIP
87	1	2151700	WASHER- EYE SHAFT(.562 OD)
89	1	2994496	FOOT PEDAL/PLUG ASSEMBLY
90	1	2993705	PUSH- BUTTON MAGNET ASSY
91	1	2302732	SPRING- LOWER PEDAL
92	1	2260810	CLIP, REED SWITCH
95	1	2280115	KNOB- SPEED CONTROL (VAR)
96	1	2263000	E-RING THU-ARC
97	1	2266413	TENSION SCREW PLATE FTPEDAL
*98	1	2260511	PIN- PIVOT A/T FT PDL
99	1	2774550	FT PEDAL BASE/PIN ASSEMBLY
100	1	2262301	PULLEY- FOOT PEDAL
101	4	2223430	SCREW- #8X3/4 PPH TYPE 25 SS
103	1	2266400	COVER- PULLEY
104	4	2301310	SCREW- 8-18 X 1/2
105	1	2264056	CNTROL BOARD ASSEMBLY 24-36V MAX
106	1	2365107	INSULATING PAD (2.3X3.2)
110	2	2223455	SCREW- 10-32 X 1/2"
112	1	2261220	WIRE HARNESS AT & MAX
113	1	2267505	CABLE ASSEMBLY- RIGHT (5')
114	1	2267515	CABLE ASSEMBLY- LEFT (5')
115	1	2265430	CABLE JACKET (5')
116	1	2265110	BOOT- CONTROL BOX
117	1	2265115	BOOT- FOOT PEDAL BASE
118	2	2372100	SCREW- 8-18X5/8 THD
119	2	2261714	WASHER- MAXXUM FT PDL
120	1	2261901	BRACKET- CONDUIT
121	1	2263210	BRACKET- CONDUIT ADJUST
122	1	2263104	NYLOCK KEEPER
123	1	2263463	SCREW- 1/4-20X2" STL PPH
124	1	2261233	LEADWIRE- A/T VARIABLE
124A	1	2060310	FUSED GROUND WIRE
126	2	2020700	TERMINAL RING- 3/8"
127	1	2256300	TIE WRAP- 5.5' BLACK
128	2	2263201	CLAMP WIRE HARNESS MICRO
129	1	2332103	SCREW- 6-20X3/8 THD (SS)
133	1	2254031	SWITCH- MOM/OFF/CON
134	1	2266412	SWITCH PLATE- FT PEDAL
135	2	2332103	SCREW- 6-20X3/8 THD SS
136	2	2256301	TIE WRAP- 5.5" WHITE
137	1	2774511	BOTTOM PLATE- MAXXUM FT

ITEM	QTY	PART NUMBER	DESCRIPTION
138	5	9953104	SCREW-8 X 1/2" (SS)
139	4	2263455	SCREW- #12-14X1/2 THR FRM
140	4	2265126	BUMPER PAD- FOOT PEDAL
141	1	2266610	DECAL- ON/OFF SWITCH
142	1	2282500	CONTROL BOX- PLASTIC
143	2	2267800	GEAR- INDICATOR
144	1	2262221	INDICATOR- DRIVE
145	1	2261905	BRACKET/INDICATOR
146	1	2301310	SCREW- 8-18X1/2"
147	1	2264015	LIGHT/INDICATOR
■	1	2991550	CLAMP COLLAR ASSEMBLY
148	1	2071550	CLAMP COLLAR "A"
149	1	2071555	CLAMP COLLAR "B"
150	1	2072621	PIN-KNURLED
151	1	2281505	KNOB-CLAMP COLLAR
153	1	2071718	WASHER #10 NYLON RETAINING
155	1	2073102	NUT - HEX 1/4-28 SS
156	1	2071560	SPLIT COLLAR
158	1	2263804	STRAP - VELCRO 30.5"
200	1	2075120	URETHANE PAD
205	2	2261540	INSERT-THREADED BOWPLATE
210	2	2335400	SHRINK TUBE-1/2" OD X 2"
215	1	2375400	SHRINK TUBE-1/4" OD X 1 3/4"

■ THIS ITEM IS PART OF AN ASSEMBLY.

*THIS ITEM IS PART OF A KIT AND ONLY LISTED FOR VIEWING PURPOSES.

MOTOR WIRING DIAGRAM

NOTE: This is a universal, multi-voltage diagram. Double-check your motor's voltage for proper connections. Over-Current Protection Devices not shown in this illustration.

Maxxum 70 is 24-volts only!

VARIABLE SPEED CONTROL BOARD

OPTIONAL BROWN WIRE FOR MOTORS WITH 70 LBS THRUST AND HIGHER. SEE BOAT WIRING DIAGRAM.

